





***Are you searching for the ultimate solution for an easy and quick set-up for training and presentation on site?***

**The bigger... higher, the better... But how to handle? Bigger and higher also means more handling and increasing risks. The available sizes and weights of current available flat panels, make it a hard job to control and install these giant products. The moment a flightcase opens, the chances of risks increase.**

**Combining more than 25 year of experience in flightcase building and being specialist on presentation solutions, the Stack-Lift® is the ultimate combination of Audipack trades.**



## The product

To offer a profitable and valuable solution that contributes to a "presentation on a higher level", Audipack has introduced a new product line called the Stack-Lift. Assemble the Stack-Lift without using any tool and enjoy and benefit the luxury and rigid appearance.

The Stack-Lift range combines a presentation product for medium sized flat panels with ergonomic personal use.

On every location, this lift system is able to assist during the installation of a flat panel up to any height on the column.

Audipack has combined a rigid flightcase packaging and presentation in one. Using the known Audipack Lock 'n Secure L&S3 and L&S5 mounting system any brand and type flat panel can effortlessly be installed.

Simply "stack" the components on each other (just like the 390908 floor stand) without using any tool!

Click the manual hoist to the column, and raise the flat panel out of the flight case and install your screen up to a maximum height of 2750 mm.

There is also a dual Stack-Lift available for the larger and heavier flat panel displays.

## Benefits:

- ▲ Install your flat panel with just 1 person
- ▲ No personal lifting
- ▲ No tools needed for assembly
- ▲ Continuous height adjustment
- ▲ Landscape or portrait positioning of the flat panel
- ▲ Integrated yet easily accessible cable channel
- ▲ Available as an upgrade set for 900 series



**Be head and shoulders above the crowd, simply use the Stack-Lift®.**

#### Technical specifications:

Product code: 390966

Max. load single stand 60 kg

Max. floor stand height 2750 mm

#### Accessories:

##### Flightcase

- Flightcase for your flat panel and floor stand  
Available in your colour, size and shape



##### Portrait-landscape rotatable adaptor

- Flat panel landscape-portrait rotatable adaptor. Manual 90° rotation of the flat panel.  
Max. load 80 Kg  
Part. no \_\_\_\_\_ P3496

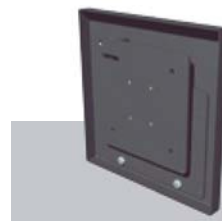

##### Upgrade set

- Upgrade set to convert your standard 390908 floor to an Audipack Stack-Lift.  
Part. no \_\_\_\_\_ 390965

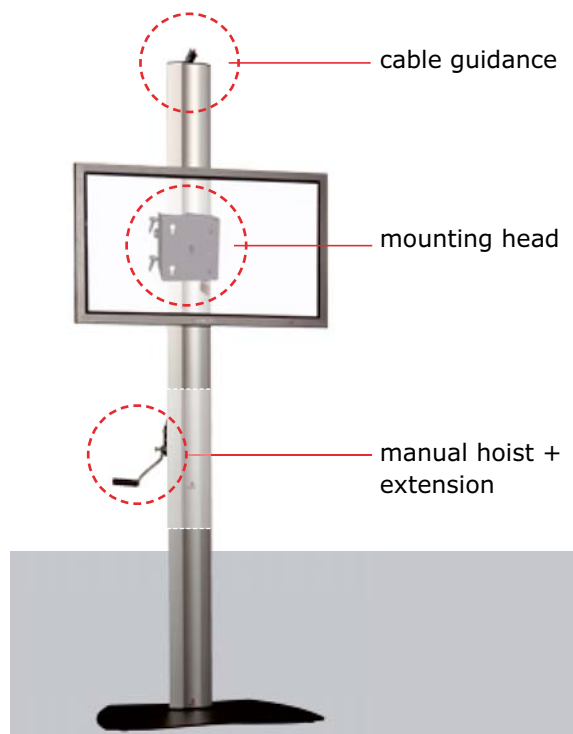

Separate brochures are available for:

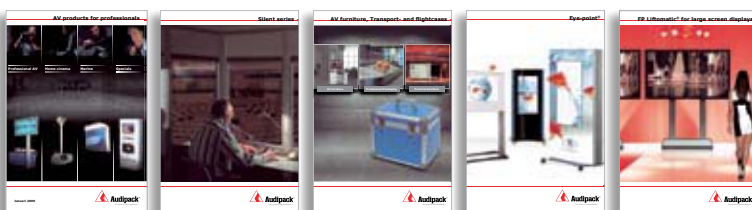

AP/SL/EN/V1.0/2009



Industriestraat 2  
NL-2751 GT Moerkapelle  
The Netherlands  
Tel. +31795931671  
Fax +31795933115  
audipack@audipack.com  
www.audipack.com

Your Audipack® dealer:

monitorhalterung.de  
Schnackenburgallee 41b  
22525 Hamburg  
Tel.: +49 (0) 40 - 500 505 60  
Fax: +49 (0) 40 - 500 505 61  
E-Mail: info@monitorhalterung.de  
Shop: www.monitorhalterung.de